

***Just to add, you WONT be electrocuted in any of these procedures !!!!!!!***

**STEP - 1**

This one is for a Bravo before 1999 (mk1) - it has push contacts on the boot, the 1999 up (mk2) dont have them so you don't need to look for them

How to: **the car key must be OUT of the key hole (engine turned off)**  
open the boot and locate the contacts, they will look like this. Circled red.

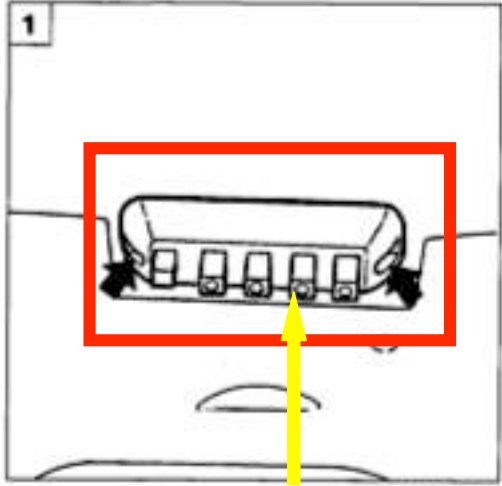
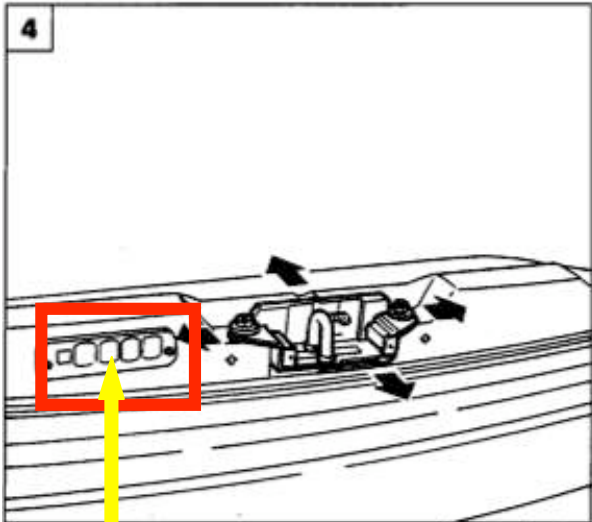

 <p>1</p>	<p>On this element that is on the boot, you have to clean the tips of the contacts. Pointed with a yellow arrow. To do it, use some fine sand paper.</p>
 <p>4</p>	<p>On this element that is on the car chassis, near the lock hinge. You need to clean the square plates with a fine sand paper. Yellow arrow.</p>
<p>After you have done that, do the next step.</p>	

## STEP – 2

For all bravos.

Take out the rear bulb holders. And do the following.

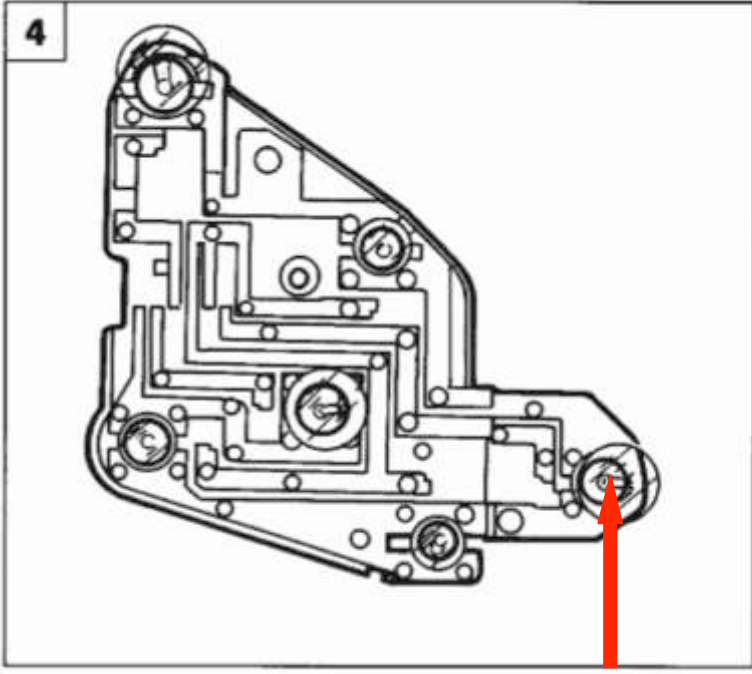
**the car key must be OUT of the key hole (engine turned off)**

 <p>The diagram shows a cross-section of a rear bulb holder assembly. A red arrow points to a specific contact point in the center of a hole where a bulb would be inserted. The number '4' is in the top left corner of the diagram area.</p>	<p>Take out all of the bulbs. Take some pliers and lift the middle contacts up. But be gentle so you don't break them.</p> <p>I mean the contacts that are in the center of the holes where the bulb goes.</p> <p>You can probably see it, where the red arrow points.</p>
 <p>A pair of yellow-handled pliers with silver metal jaws, shown from a side-on perspective.</p>	<p>These are the pliers. You don't need to use them, but use something similar so it can go in the hole.</p>

### STEP – 3

This is the most important step to do and it involves a bit more work.  
Again **the car key must be OUT of the key hole (engine turned off)**

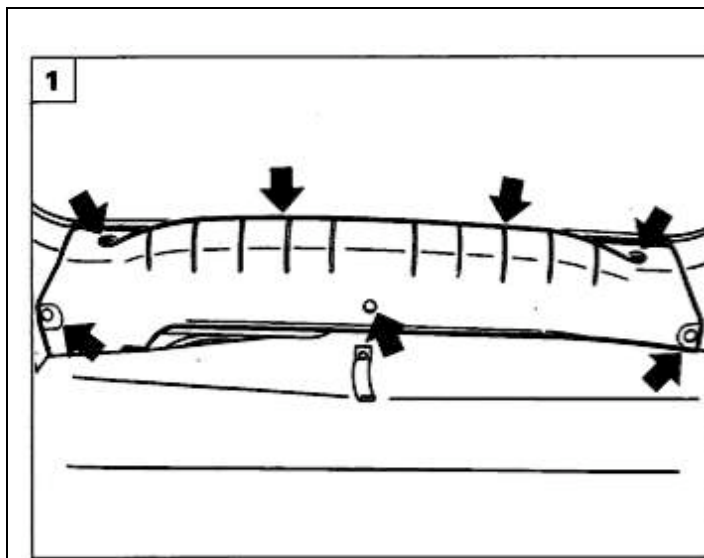

To get the access to the earth wire you must remove this. It's the boot plastic lid on the chassis of the car.

To do so, remove the screws that are pointed with arrows.

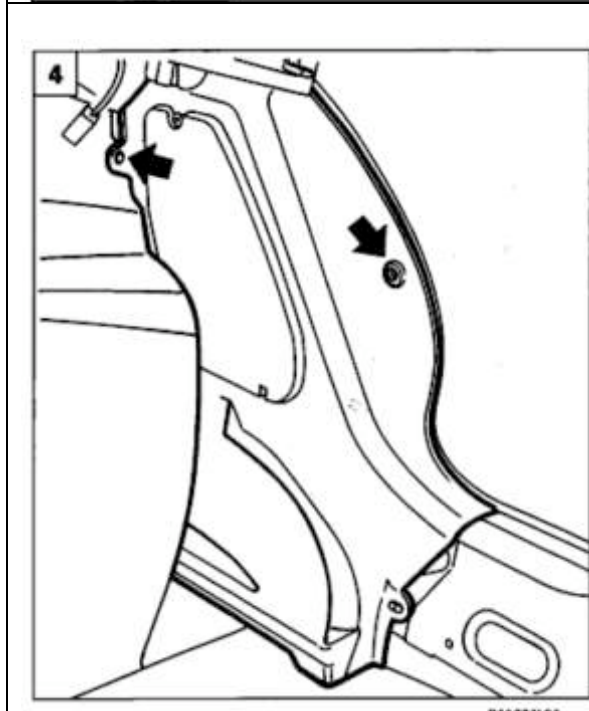

After you have removed the above.

You must remove one more thing.  
The plastic that covers the rear light cluster.

To do so, remove the screws pointed with black arrows.

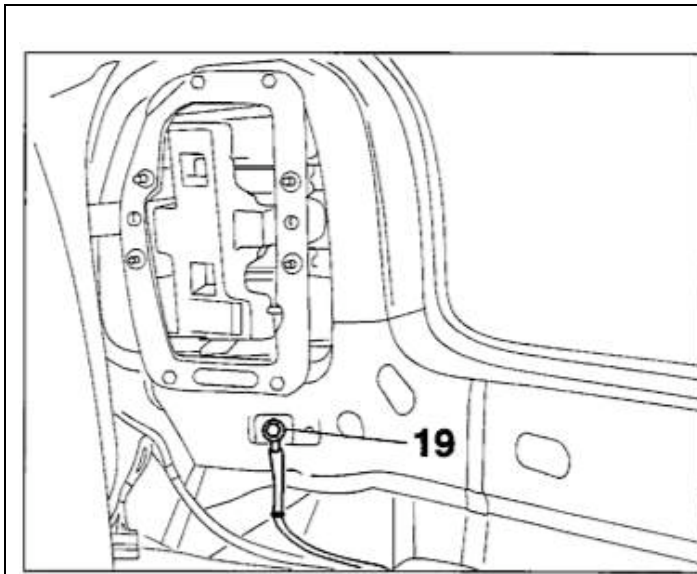

After you removed the above, you will see something like this.

The number 19 on the pic is the earth.

Clean it with some sand paper, both sides. Mean the one that is on the wire and the place where it sits on the chassis. And clean the screw also.

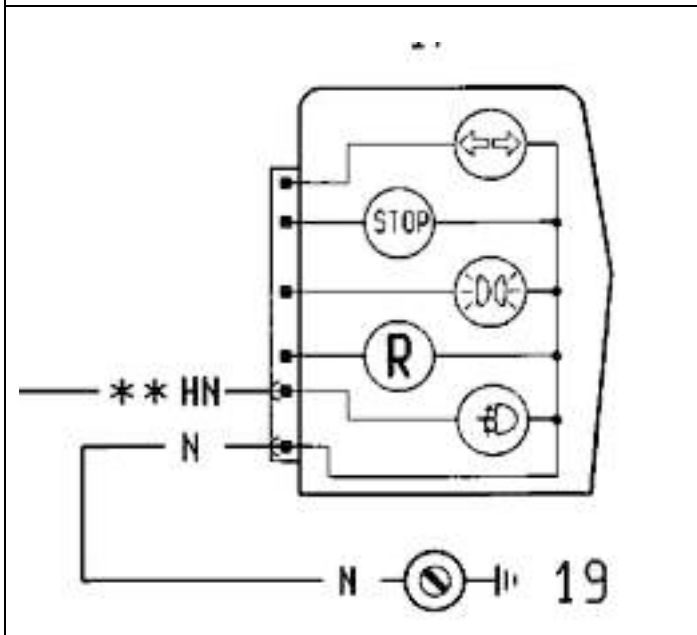

This is the rear cluster shown like a schematics pic.

The earth is the nr. 19.

Now when you have done the 3 steps, put the key in the ignition and try if all works fine.

**If not**, clean the earth contacts again, or pull another wire from where ever you like of the cars chassis to the existing earth.

**If yes**, put the plastic covers back on. And you are done. ☺